

REV	DESCRIPTION	DATE
01	Issue	20/06/2011
02	Issue	20/06/2011
03	Issue	20/06/2011
04	Issue	20/06/2011
05	Issue	20/06/2011

LIBRARIAN STATION

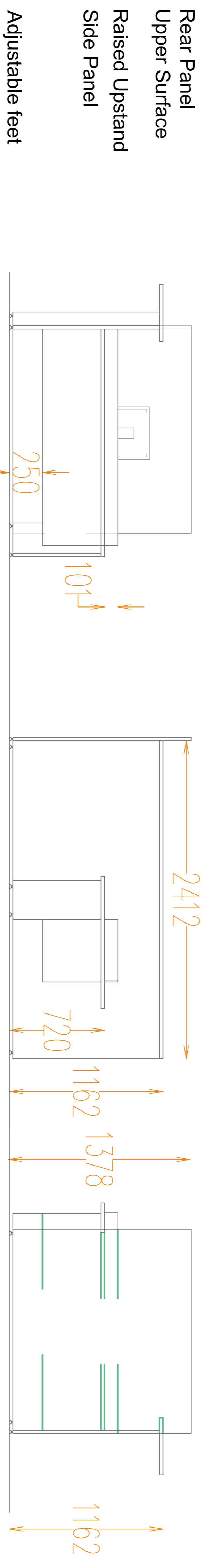

Details
 Finish to be 25mm mdf, veneer to be as SAMPLE B provided to Serota Libraries
 Edge detail to be square pencil rounded edge all round
 Desk surface to include all round grommet - position indicated
 Curved upstand to desk front to be approx 12-15mm thick to match front curve of desk surface

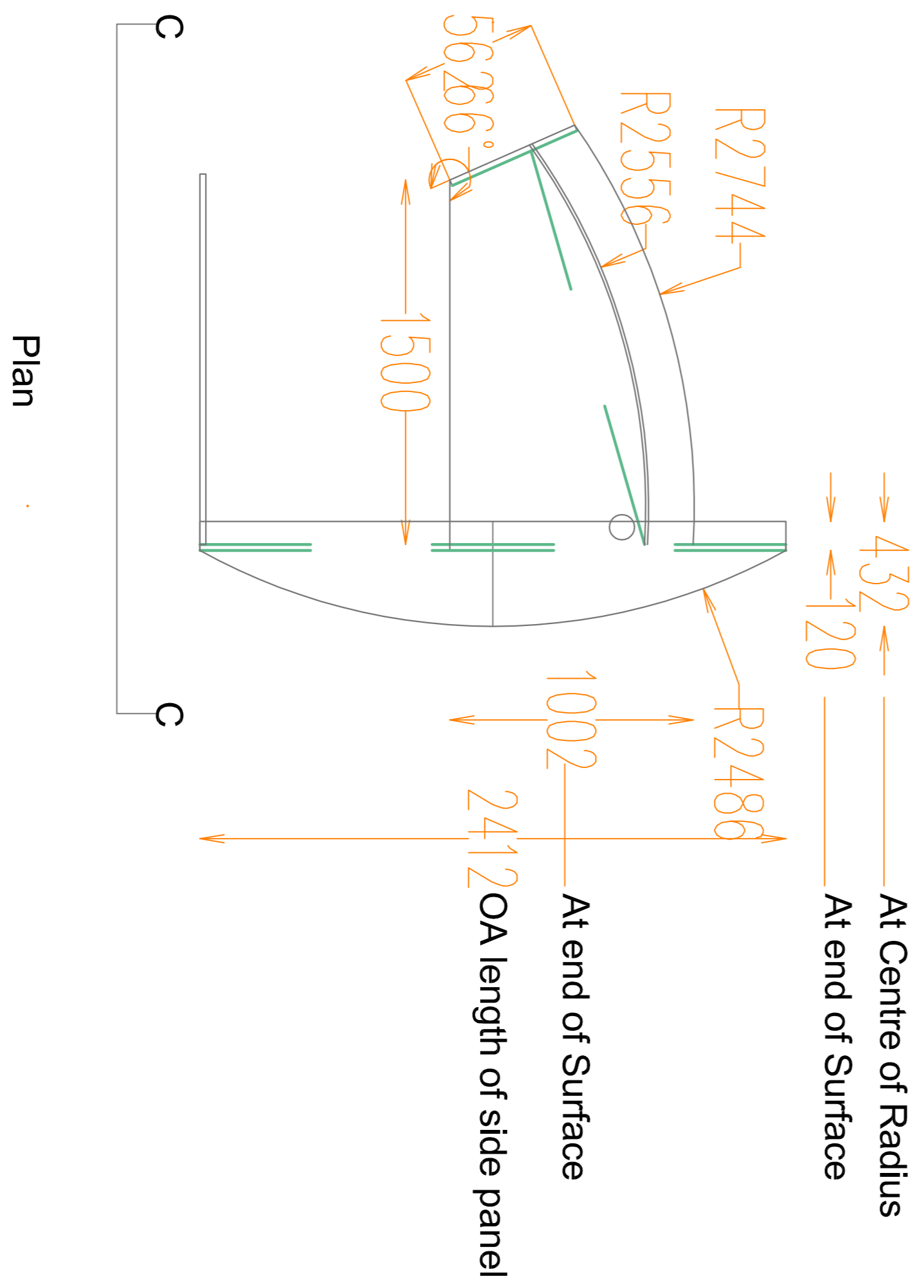
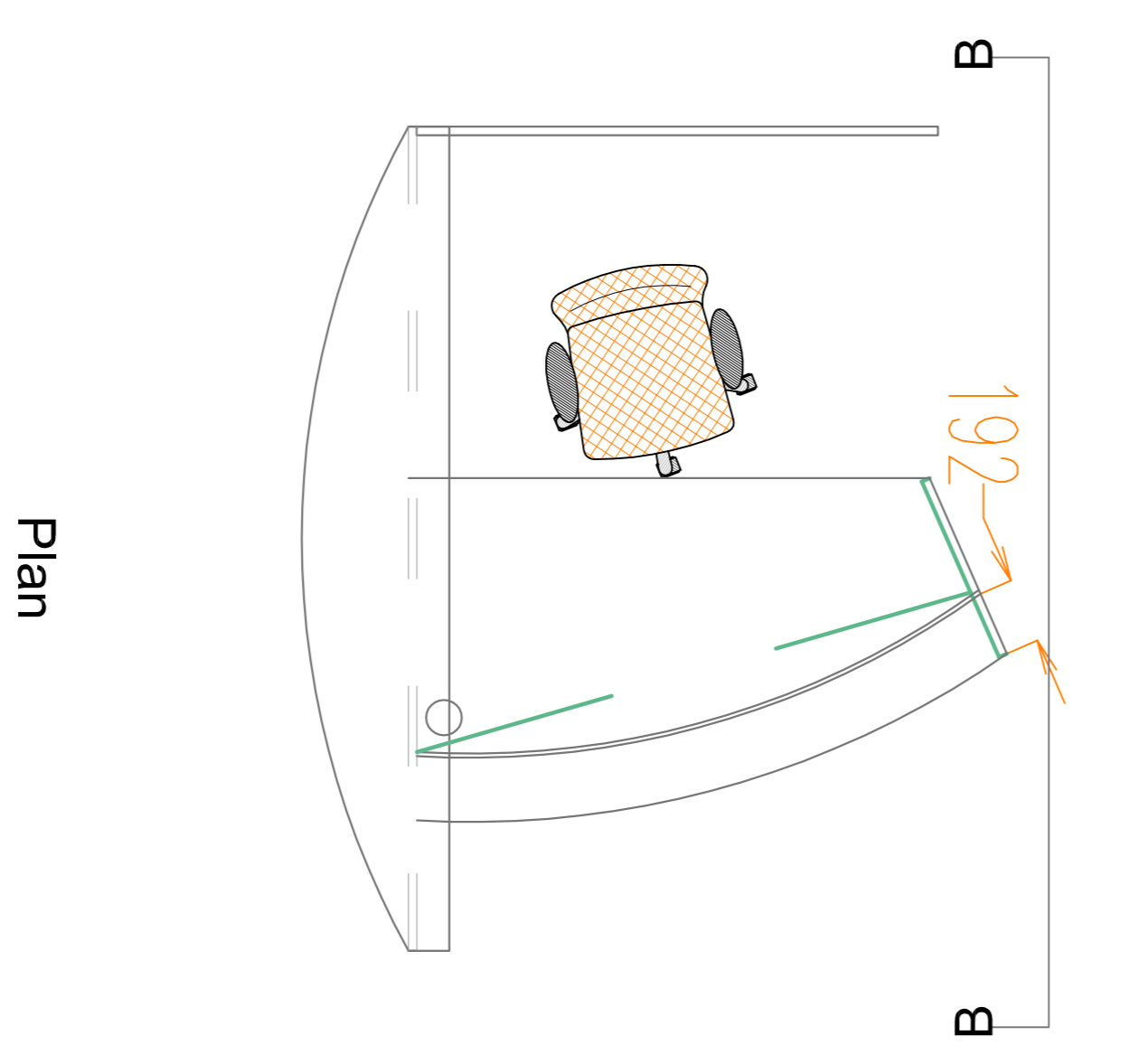
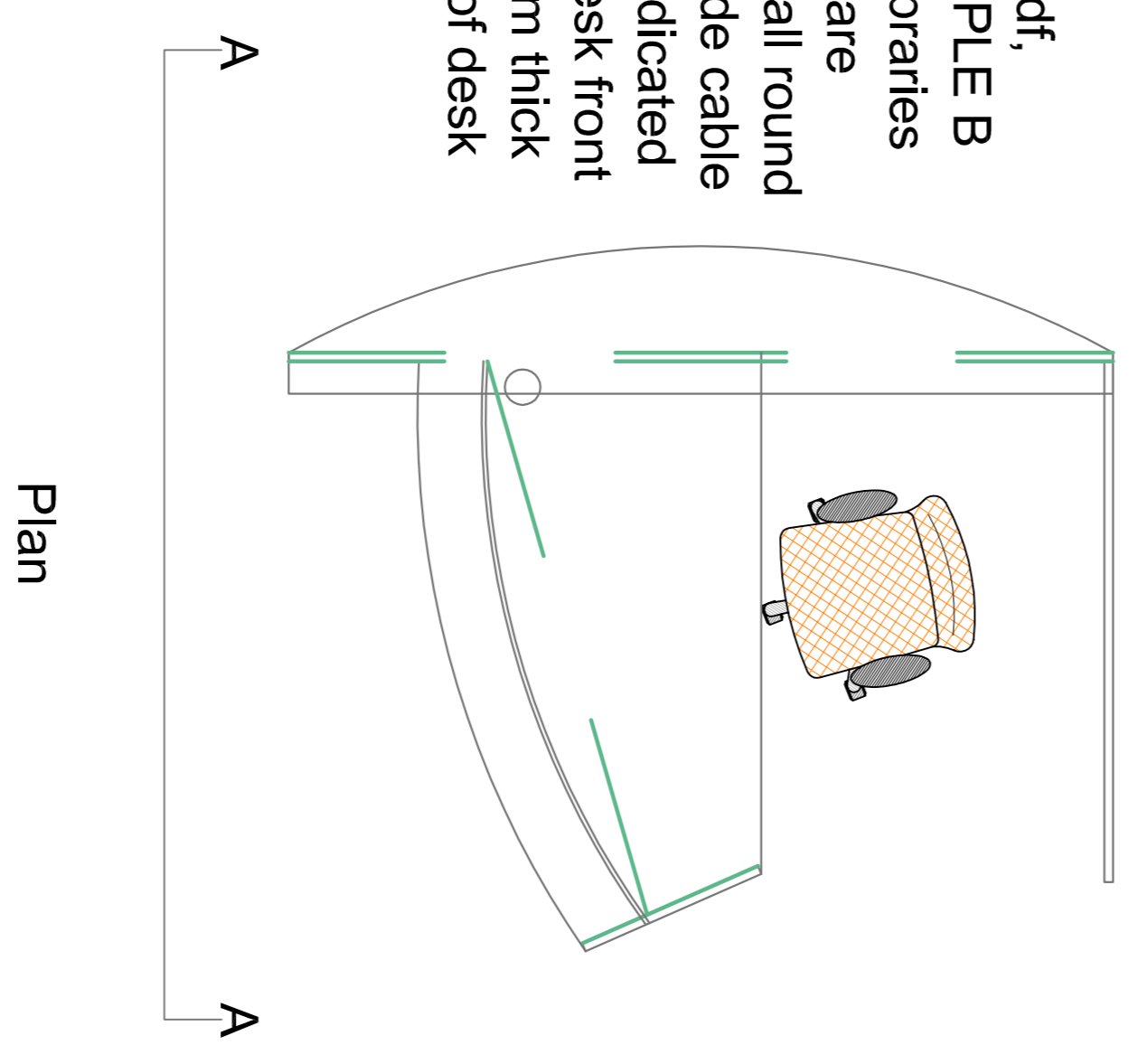

chris levings fcsd

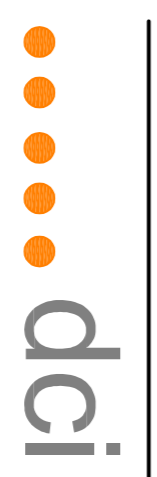

interior architecture fresh unique inspired planned designed built

Client: Serota Libraries
 Job: Chatham House Members Library
 Date: 20/06/2011
 Drawing: Production Details

Commercial Retail Domestic Health Care
 Scale: 1 = 20
 Date: 20/06/2011
 Project No: DC2439/06/11
 Rev: P01.2